

3/4" x 1" Perimeter Board

1"

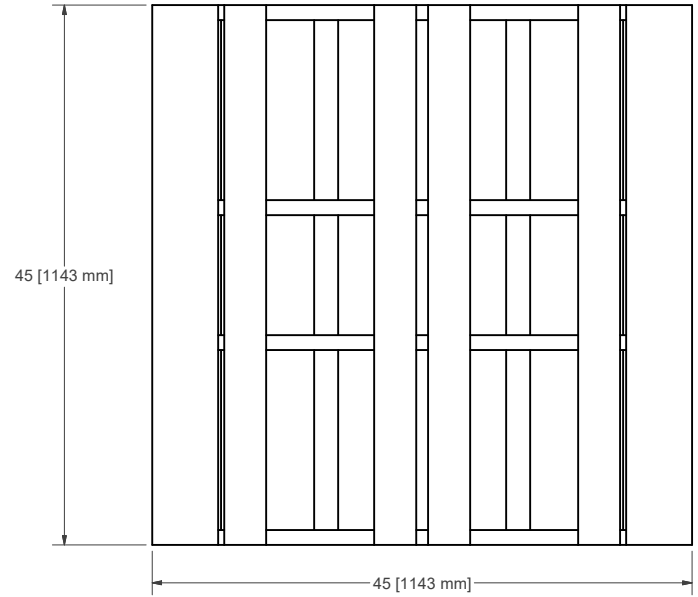
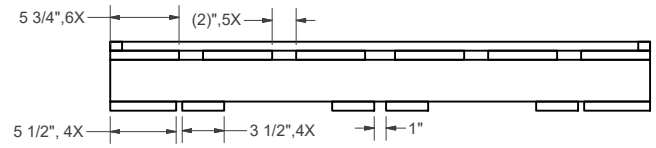

45 [1143 mm]

45 [1143 mm]

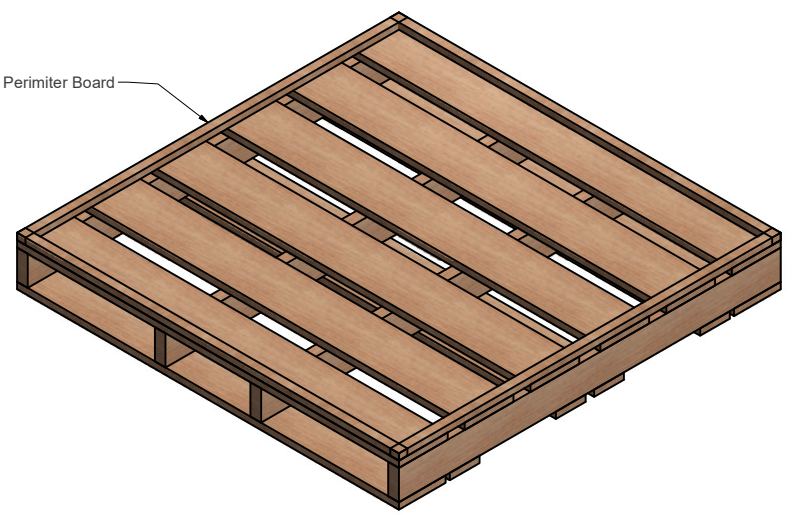

3/4" x 1" Perimeter Board

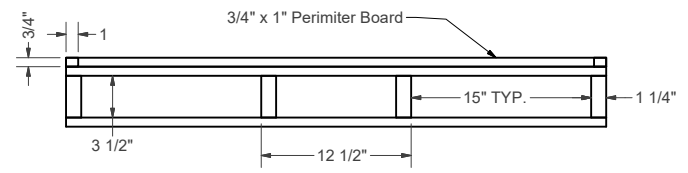

3/4" x 1" Perimeter Board

Notes:

1. Top Deck 3/4 inch Hardwood 6 Boards
2. Bottom Boards 3/4 inch Hardwood
3. Runners Hardwood 4
4. 3/4"x 1" Edge Frame
5. Hold the 13 1/2" Between Runners for Pallet Jack use

THIS REPRODUCTION IS A PROPRIETARY DESIGN AND CONFIDENTIAL INFORMATION OF PACKGEN CORP. AND IS LOANED SUBJECT TO THE CONDITIONS THAT:
 1. IT SHALL BE USED OR CAUSED TO BE USED FOR RECORD AND REFERENCE PURPOSES.
 2. IT SHALL NOT BE USED OR CAUSED TO BE USED FOR PROCUREMENT IN ANY WAY PREJUDICIAL TO PACKGEN CORP. INTERESTS.
 3. IT SHALL NOT BE REPRODUCED OR COPIED IN WHOLE OR IN PART, AND
 4. IT SHALL NOT BE DISCLOSED AS GENERAL OR SPECIFIC INFORMATION WITHOUT EXPRESSED CONSENT IN WRITING SIGNED BY AN AUTHORIZED REPRESENTATIVE OF PACKGEN CORP.

DRAWN Russ	11/21/2006	Unless otherwise specified dimensions are in inches. Tolerances are as follow: Fractional = ± 1/4, .XX = ± .020, .XXX = , Angles =	
CHECKED		TITLE 45" x 45", 2 Way Hardwood Pallet	
QA		SIZE C	DWG NO 101665
MFG		SCALE	REV 2
APPROVED		SHEET 1 OF 1	